

THE LIFE Kit

Each plastic pouch contains 1 blank data forms, two decals and information from Prepare BC. Once completed, these forms provide pertinent information regarding an individual's doctor, medical conditions, allergies and next of kin.

Each person in the household should have a completed form in the pouch. The completed forms are to be stored in the pouch which is to be kept in the fridge in the designated location.

In the event of an emergency, the LIFE Kit can be easily accessed by emergency medical personnel.

Additional helpful information, such as identification photographs and medical directives, can be optionally included in the LIFE Kit.

If you have a Living Will or DNR make sure that you have an original of your signature. Photocopies of signatures are not acceptable.

Recommendations

Update your information whenever you have any changes. It is recommended that you review this information when Daylight/Standard time changes and during Fire Prevention Week.

Where to keep the LIFE Kit

The completed pouch is to be placed inside the door of your fridge on the right-hand side. If you do not have a shelf, you may stick the pouch (with tape) to the inside of your fridge.

To alert emergency personnel that the LIFE Kit is available, a red coloured sticker is to be placed on the front of the fridge door. The second red sticker must also be placed on the entrance to the residence.

Who does the LIFE Kit help?

Since the pouch is used when people cannot reliably provide their own medical information, it is ideal for senior citizens, chronically ill persons and those who live alone. The information is equally important for young children under the care of a sitter.

The pouch can also be used by travelers in cars. For this purpose, the pouch is stored in the glove box.

Disclaimer

The LIFE Kit Committee bears no responsibility for any information provided by or excluded by the subscriber. The subscriber has sole responsibility for the information included or excluded from the kit and is responsible to ensure it is current and accurate.

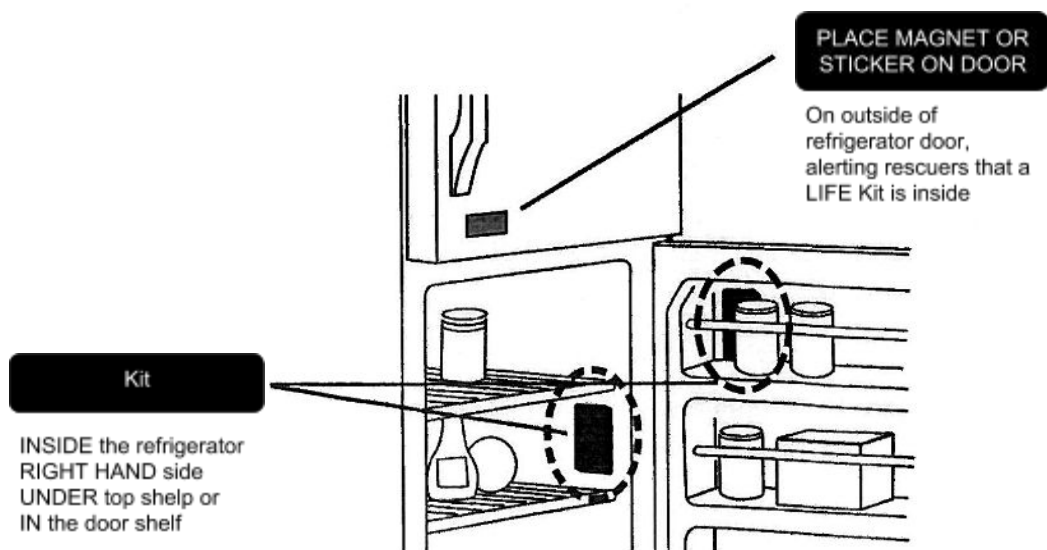

You can download and print additional LIFE Kit sheets at <https://srd.ca/services/emergency-management/>

The program has proven instrumental in saving lives!

Responders.

The program was developed by Sheriff Richard Marsh in Michigan, U. S. A. The program has great potential to save the lives of persons who are not able to communicate with Emergency

LIFE Kit

LIFE Kit

**Speaking for YOU when you
cannot speak for yourself!**

**Emergency Health
Responders**

Produced

By:

